

Design Study and Technology Assessment on Inertial Fusion Energy Power Plant

S. Nakai ⁽¹⁾⁽²⁾, M. Yamanaka ⁽¹⁾, Y. Kozaki ⁽¹⁾, T. Norimatsu ⁽¹⁾

(1) ILE, Osaka University, Yamada-oka 2-6 Suita, Osaka 565-0871, Japan

(2) Kochi National College of Technology, Monobe Nankoku-city, Kochi 783-8508, Japan

Abstract

Based on the conceptual design of Laser Driven IFE Power Plant, the technical and physical issues have been examined. R&D on key issues that affect the feasibility of power plant have been proceeded taking into account the collaboration in the field of laser driver, fuel pellet, reaction chamber and system design. It is concluded that the technical feasibility of IFE power plant seems to be reasonably high. Coordination of reactor technology experts in Japan on Laser Driven IFE Power Plant is being proceeded.

1. Introduction

Inertial fusion energy (IFE) is becoming feasible due to the increasing understanding of implosion physics and the progress of relevant technologies for the IFE power plant. The establishment of gain scaling of implosion fusion with the quantitative evaluation of the tolerable conditions on driver and fuel pellet is the most important issue. The worldwide efforts to clarify the implosion physics have given us a feasible prospect toward the achievement of fusion ignition, burning and energy gain. It should be noticed and be taken into account on the strategic approach toward IFE that fusion ignition and energy gain will be demonstrated within the next decade by the MJ laser facilities which is under construction in the USA and France.

2. IFE Power Plant

Inertial fusion energy research and development are based on a large number of advanced concepts and technologies such as drivers, pellet fabrication and reaction chamber systems.

The reactor technologies for IFE power plant have been identified and evaluated through the conceptual design studies. Various kinds of power plants can be designed with different selections and combinations of elements such as implosion scheme (that is fuel pellet), driver, and chamber. Typical candidates of each element to set up a specific power plant are listed in TABLE I. Power plant "SENRI" was reported in 1981 [1].

TABLE.I. DESIGN SELECTION OF IFE POWER PLANT AND DESIGN STUDIES AT ILE.

Implosion	Driver	Chamber	Power Plant
Direct	DPSSL	Dry Wall	— New Design
Hybrid	KrF	Wetted Wall (+thick guided flow)	— KOYO
Fast Ignition	Pulse Power	Peble	
Indirect	HIB	Thick liq. flow	— SENRI

Although it was so primitive to utilize direct drive implosion with CO₂ laser, it is unique to

utilize magnetically guided thick Li flow to form cavity protecting the first wall. Replacing the CO₂ laser with DPSSL (Diode Pumped Solid State Laser), this concept is still interesting to refine with modern knowledge on reactor technology. "KOYO" was reported in 1992 [2], which was designed taking into account the newest gain scaling of direct drive at that time, and the progress and perspective of DPSSL technology. A wetted wall that is formed with seeped out LiPb layer from guided flow in woven SiC pipes is the key concept of the chamber. The feature of system design of KOYO is the arrangement of multiple chambers to one driver. This gives us wide flexibility in optimizing the system design. The key elements of KOYO have been developed and investigated with a worldwide collaboration [3].

Fast ignition concept has interesting feature in power plant design. That is high gain with relatively small drive laser energy and smaller energy release. Instead, higher repetition is required to get reasonable average power of electricity. Dry wall concept of reaction chamber has been begun to be reexamined for the fast ignition concept and also for the central ignition concept.

3. Driver

3.1 DPSSL Development

Diode pumped solid state laser (DPSSL) is a promising candidate of reactor driver for IFE. We have newly designed a DPSSL driver HALNA 10k (High Average-power Laser for Nuclear-fusion Application) based on a water-cooled zig-zag path slab amplifier module, which can deliver 10 kJ output energy at 350 nm with 12 Hz repetition.

A 10 J x 10 Hz module, HALNA 10, has been constructed to investigate and confirm the technical key issues of this concept of DPSSL such as thermal effects, beam quality, energy flow and efficiency, and life of key elements such as cooling surface, laser slab, and diode. It can be scaled up as shown in Fig.1 to reach to a 10 kJ x 10 Hz module that consists of 15 Beamlet with phase coupled beam combining. The development of high power LD (Laser Diode) is being proceeded keeping connection with industrial application.

M. Yamanaka reports the details of 10 J x 10 Hz module and its first results at IAEA-CN-77-IFP/03 [4]. The progress of single shot based laser for ICF research and high average power laser with repetitive operation of IFE power plant is shown in Fig.2.

3.2 Uniformity Improvement for Solid State Laser Driver

The applicability of solid state laser as to the reactor driver strongly depends on the capability to achieve uniform irradiation onto the fuel pellet for its stable implosion. Several important concepts and technologies for a better irradiation are under investigation such as pulse shape control with PCL (partially coherent light) foot and coherent main pulse, and phase and spectral control of high power main beams.

Fuel pellet design in conjunction with the driver specification for a better fusion implosion is one of the most important issues in the near future for the laser fusion energy development. Better uniformity than 1 % can be expected with increasing beam number and spectral width of glass laser. Fig. 3 shows some combination of driver beam and fuel pellet structures [5] to mitigate driver nonuniformity for uniform implosion.

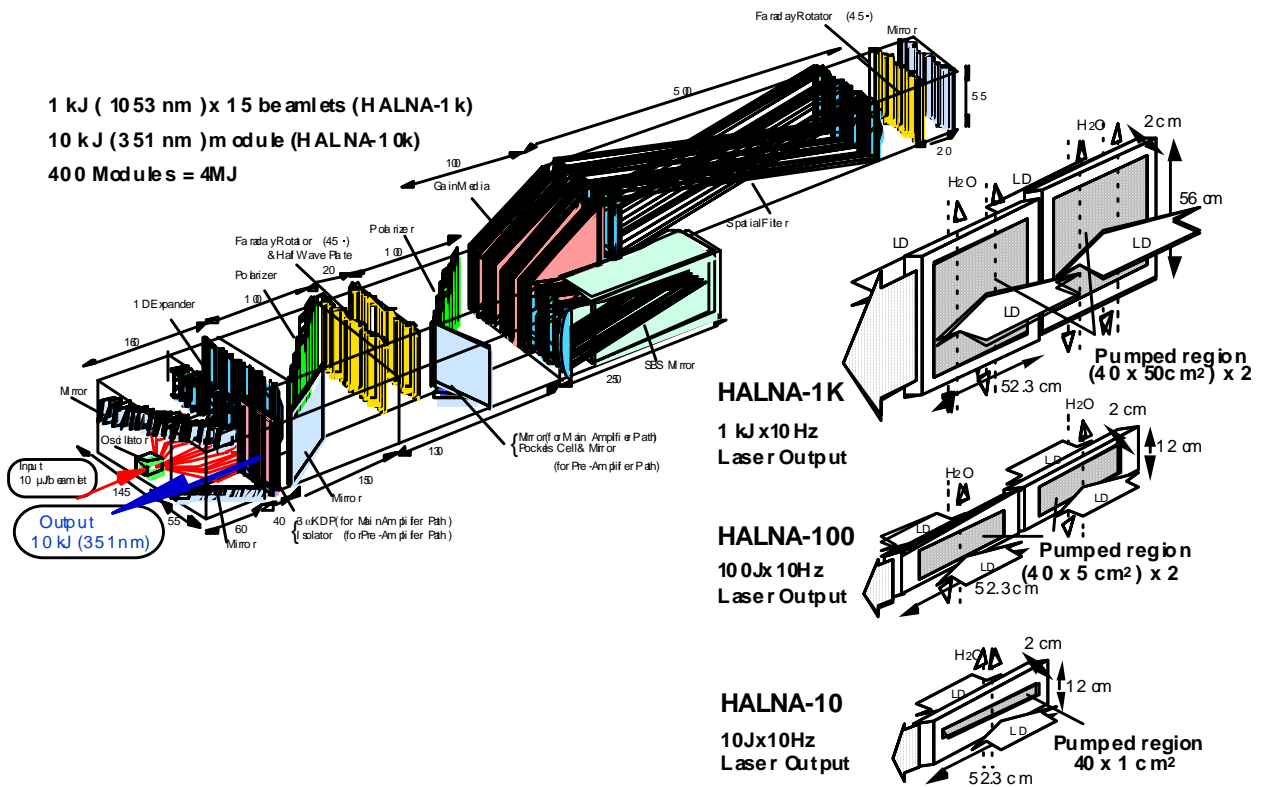

FIG. 1 Development plan for reactor driver module of 10 kJ x 10 Hz starting from equivalent mini-module of 10 J x 10 Hz.

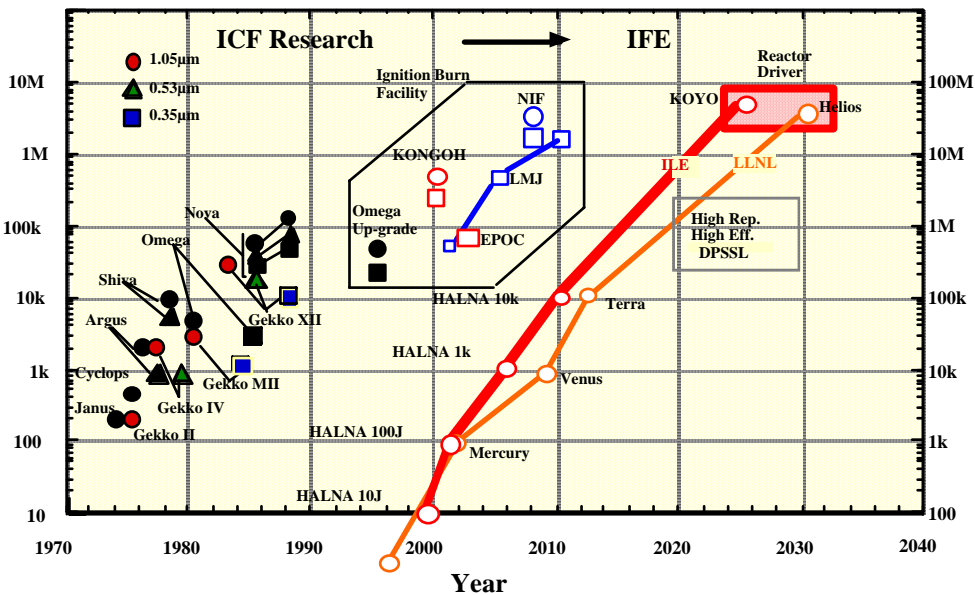

FIG. 2 Progress of ICF and IFE laser drivers.

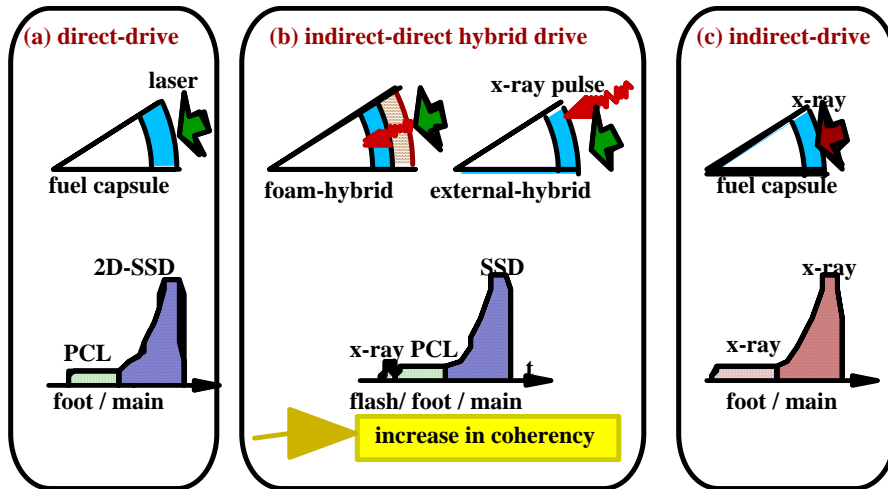

FIG.3 Combination of various fuel pellet and structure of driver radiation to mitigate the effect of drive nonuniformity.

4. Reaction Chamber

4.1 Requirement to Chamber Environment

Design studies and economic analysis of laser fusion power plants show that it is necessary to achieve pulse repetition rate more than 3~10 Hz for economically attractive power plants [6]. This pulse repetition rate is limited by the time of restoring chamber environment. The residual gas at the time of the next pellet injection may disturb the trajectory of the injected pellet and the laser beam propagation. Then the pulse repetition rate of the liquid wall chamber concept is limited by evacuation speed of metal vapor that is ablated from liquid metal wall with the x-rays and the plasma produced by fusion burning.

The requirements for the vapor pressure not to disturb pellet injection and laser irradiation are considered to be less than $10^{-2} \sim 10^{-3}$ Torr [7].

4.2 Physics of Chamber Dynamics

The chamber wall of inertial fusion power plant is subjected to the pulses of X-rays, neutrons, and charged particles produced by fusion burning. For protecting the chamber wall from these products, various liquid wall concepts in which the first wall is covered with liquid metal have been considered.

For the liquid wall design, it is necessary to restore the chamber environment enough to make laser beams propagate and illuminate the target precisely and make pellet injection straight without its surface charged with vaporized gas. Fig. 4 shows the major subjects to be studied.

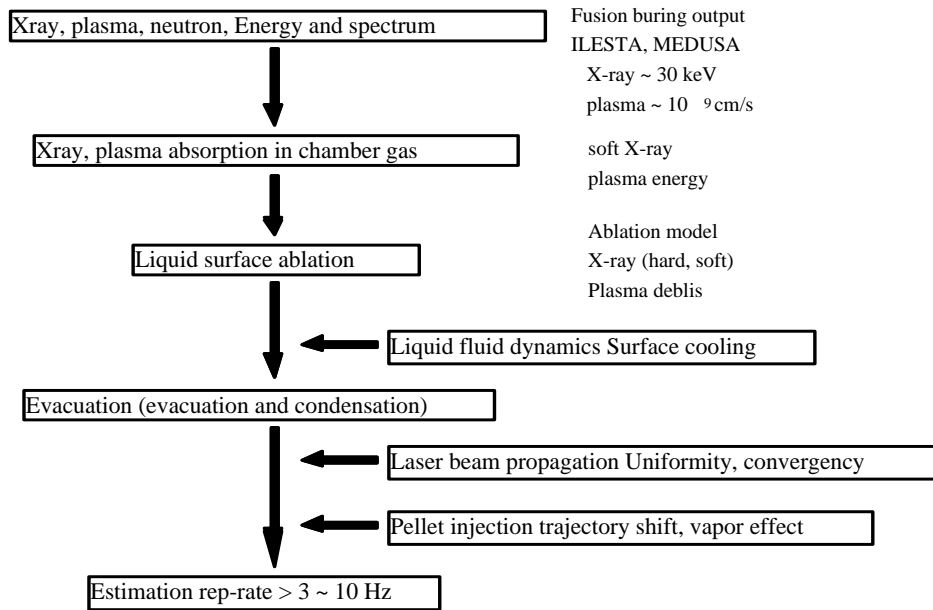

FIG.4 Issues and major subjects on liquid wall chamber.

When the microexplosions occur at the center of the chamber, the high energy X-rays, neutrons and charged particles are emitted. The pellet material plasma, CH and DT, are heated up to several 10keV by mainly alpha particle. The emitted plasma of which averaged velocity is $\sim 10^9$ cm/sec penetrate ablated plasma in ~ 1 ns, and pass through chamber gas in ~ 400 ns. These plasma, hard X-rays, and re-emitted soft x-rays are stopped in the liquid metal film which cover the first wall material and deposit their energy.

In KOYO reaction chamber, at 13ns after explosion X-rays reach the liquid metal film but the hard X-rays with long penetration depth don't cause ablation of liquid metal. At 100 ns neutrons penetrate the first wall deeply and slightly deposit its energy to first wall. At 400 ns after explosion charged particles hit the wall. These cause the shock heating of first liquid film and evaporate it.

The metal vapor expands to the center and gets reached in 1~3 ms. On reaching the center, it begins to convert kinetic energy into heat, and also expands to the wall. While the gas moves oscillatory, being reflected at the wall and center, the chamber gas is evacuated down to 10^{-2} Torr. For estimating evacuation speed, the simulation of chamber gas dynamics, which mainly depends on the conditions of ablation and surface temperature of the liquid wall, is key issue [8].

4.3 Dry Wall Concept with Various Protection Schemes

If the dry wall chamber can contain the repetitive micro-explosions which release reasonable average fusion power for longer period than several years, we can design very attractive power plant with less ambiguity on liquid wall chamber [9].

Following to the implosion and fusion explosion of a fuel pellet, a successive pulse energy flow hits the first wall of the chamber. They are reflected or scattered laser light, X-ray from fusion plasma, neutrons, and the plasma debris. The energy spectrum and pulses shapes of each energy species for typical high gain implosion are estimated with burning simulation

code. The dynamic responses of several dry wall materials such as C, V, Fe, and Ta are analyzed to examine the possibility to be used as the first wall of a reaction chamber.

The dry wall seems to survive against the energy fluxes of laser light, X-ray, and neutrons emitted from moderate fusion explosion with reasonable separation of the first wall. The heating and sputtering of the wall surface by plasma debris need more investigations to clear the response and life of the first wall. It should be noticed, however, that a distributed magnetic field or low-pressure gas in the cavity could mitigate the plasma flow hitting the wall for a longer life of a wall.

The capability of higher repetition of a dry wall chamber, together with multiple chamber concepts, can reduce over all cost of power plant by increasing the utility of the expensive laser driver. We are now proceeding detailed evaluation of the dry wall chamber and conceptual design of a laser driven dry wall power plant as shown in TAB.I.

5. Fuel Pellet

Precision fabrications of plastic fuel pellet to contain fuel inside have been well developed [T. Norimatsu:IAEA-CN-77-FTP/07] [10]. The DT fuel layering technologies are under developments.

The next step toward the power plant development is to demonstrate repetitive injection, tracking and shooting with repetitively fired laser. Mass production of fuel pellet with low cost is also important issue for realistic IFE power plant.

The effects of residual gas in the chamber onto the flying pellet are evaluated. They are coating effect on low temperature fuel pellet, heat flow by gas and radiation, disturbance to the flight trajectory. It can be concluded that 3 Hz operation of a liquid wall chamber is acceptable. The pressure of protecting gas for dry wall chamber must be optimized to increase the protection effect.

6. Conclusion

The key components and issues for IFE power plant are shown in Fig.5 illustratively for planning the Integrated Reactor Engineering experiment. With the progress of driver HALNA development from 10 J to 100 J and 1 kJ, the chamber and fuel pellet issues can be investigated more precisely and quantitatively. The Monbusho (Ministry of Education, Science and Culture) has given a grant in aid in 1999 fiscal year to coordinate a collaboration organization for IFE power plant technology in Japan and to respond to the international collaboration schemes for IFE development. ILE (Institute of Laser Engineering) has been proceeding IFE power plant development with the nationwide collaboration of the universities and industry keeping the framework so called "Reactor Technology Network for IFE" with the support of NIFS (National Institute of Fusion Science)

The IFE power plant technology issues and the corresponding key persons who are responsible to coordinate the Japanese activity are listed in Table II.

TABLE II. IFE Power Plant Technology Network in Japan

Steering Member	S. Nakai, T. Yamanaka, K. Mima
Driver	
DPSSL	M. Yamanaka (ILE Osaka U.)
KrF	Y. Owadano (ETL)
Fuel Pellet	
Fabrication Injection & Tracking	T. Norimatsu (ILE Osaka U.)
Tritium	T. Tanaka (Tokyo U.)
Reaction Chamber	
Liquid wall Dry wall	Y. Kozaki (ILE Osaka U.)
Reactor material	A. Kooyama (Kyoto U.)
Neutronics	T. Iida (Osaka U.)
System and ESE issues	
System design	H. Nakajima (Kyushu U.)
ESE issues	K. Okano (CRIEPI)

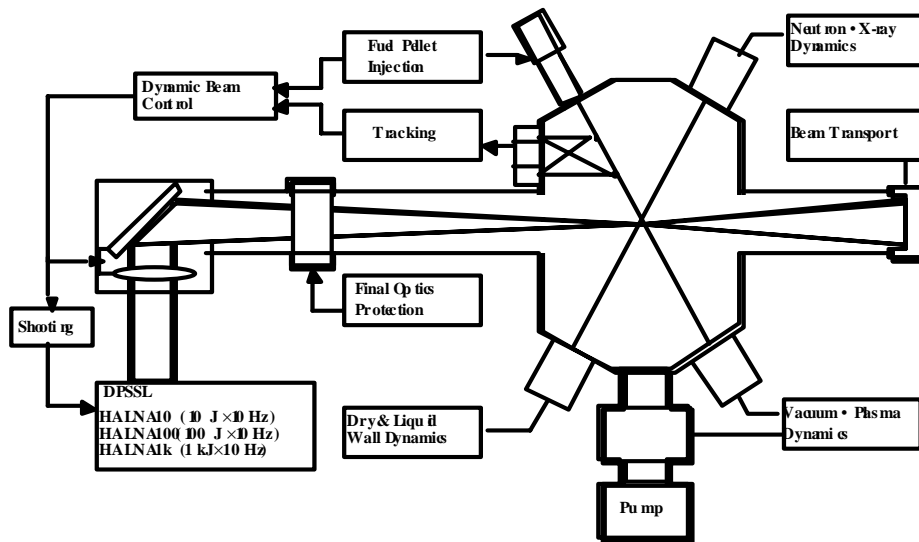

Fig.5 Integrated Reactor Engineering R&D for IFE power plant.

References

- [1] C. Yamanaka et al., "Concept and Design of ICF Reactor -SENRI-I", Rep. ILE-8127p, Inst. of Laser Engineering, Osaka (1981).
- [2] K. Mima, et al., "Design of Inertial Confinement Fusion Reactor Driven by Laser Diode Pumped Solid State Laser", Plasma Physics and Controlled Nuclear Fusion Research

- (Proc. 14th Int. Conf. Würzburg 1992), Vol.3, IAEA Vienna (1993) 381.
- [3] S. Nakai, et al., "Development of Laser Fusion Power Plant KOYO", 16th IAEA Fusion Energy Conference IAEA-CN-64/G1-3/GP-17, Montreal, Canada, 7-11 Oct. 1996.
 - [4] M. Yamanaka et al., "Laser-Diode Pumped Nd Glass Slab Laser for Inertial Fusion Energy", 18th IAEA Fusion Energy Conference IAEA-CN-77/IFP-03, 4-13, Oct. 2000, Sorrento.
 - [5] H. Nishimura et al., "Indirect Direct Hybrid Target Experiments with GEKKOXII Laser", 17th IAEA Fusion Energy Conference IAEA-CN-69/IF/04, Yokohama, Japan, 19-24 October 1998.
 - [6] Y. Kozaki, et al., 17th IAEA Fusion Energy Conference IAEA-CN-69/FTP/18, Yokohama, Japan, 19-24 October 1998.
 - [7] Y. Kozaki, et al., Proc. 7th Int. Conf. on Emerging Nuclear Energy Systems, pp. 76, 1994.
 - [8] Y. Kozaki et al., "Simulation Study on Evacuation and Effects of Metal Vapor in Laser Fusion Liquid Wall Chamber", 18th IAEA Fusion Energy Conference IAEA-CN-77 /FTP1-27(R), 4-13, Oct. 2000, Sorrento.
 - [9] S. Nakai, et. al. 18th IAEA Fusion Energy Conference IAEA-CN-77/FTP1/26, 4-13 October 2000, Sorrento
 - [10] T. Norimatsu et al., "Development of High Quality Plastic Fuel Shells for Laser Fusion Energy", 18th IAEA Fusion Energy Conference IAEA-CN-77/IFP-07, 4-13, Oct. 2000, Sorrento.