

# Advanced Design Studies Plans

---

**Farrokh Najmabadi**

VLT PAC Meeting

December 15 & 16, 1999

Sandia National Laboratory

Albuquerque

Electronic copy: <http://aries.ucsd.edu/najmabadi/TALKS>

ARIES Web Site: <http://aries.ucsd.edu/ARIES>

# Program Elements

---

- Strategic planning and forecasting -- role of fusion energy in a sustainable global energy strategy.
  - \* A new initiative in FY99, (\$555k in FY99, \$275k in FY00)
- **Power Plant Studies:**
  - \* National power plant studies team (ARIES). New projects started in 1/99 (\$1,760k in FY99, \$1,860k in FY00 including \$400k for IFE studies).
    - Neutron Source Study;
    - ARIES-AT;
    - Integrated Analysis of IFE chambers.
  - \* Pre-conceptual designs and analysis of critical issues of advanced fusion concepts (no new studies in FY99).

# Role of Fusion in a Sustainable Global Energy Strategy

---

- Most of the socioeconomic studies were launched in FY 99:
  - \* Study of options to deploy large fusion power plant including hydrogen production and co-generation. (ORNL & Partners). To be completed in 12/99. No funding in FY00.
  - \* Establish the merits and address issues associated with fusion implementation (PPPL).  
Some results were presented at snowmass.
  - \* Macro-economics modeling of global energy market and role of fusion (PNL) (Continuation of previous work).
  - \* Comparison of various sources of energy based on equivalent CO<sub>2</sub> emission (U. Wisc.).

# PPPL Fusion Energy Studies

## (J. Schmidt et al)

---

- We have developed fusion scenarios with the objective of significantly reducing carbon dioxide emissions near the end (e.g. during the last quarter) of the next century.
  - These scenarios were measured against the IPCC emissions objectives.
  - The materials, funding and tritium requirements for these scenarios have been developed.
  - The waste production has been quantified and compared to present waste production and storage.
  - The scenarios can be characterized by their schedule for commercializing fusion, and their requirements on the doubling time for commercialized fusion power.

# PPPL Fusion Energy Studies (J. Schmidt et al)

---

- We conclude from these studies that it will to be possible, but very difficult, for fusion to significantly impact carbon dioxide emissions during the next century.
  - We conclude that if we are able to reduce carbon dioxide emissions, then the resource requirements and waste disposal should be manageable problems.
- We need to study this further and decide whether fusion can meet the ambitious requirements for reducing carbon dioxide emissions during the next century, or make the case that fusion can be the energy source of the twenty-first century.

# PPPL Fusion/Fission System Studies

## (J. Schmidt et al)

---

- Fission waste disposal and associated weapons fuel proliferation are major roadblocks to fission implementation.
- On the other hand, waste and actinide burning isolated from (i.e. as an add on to) energy production carries the burden of reprocessing, proliferation potential and significant added cost.
- We have shown that, by the virtue of the fusion neutrons, a fission/fusion hybrid can achieve a factor of four increase in burn up of fuel relative to a pure fission cycle.
- We have shown that, by the virtue of the fusion neutrons, a fission/fusion hybrid can achieve a factor of four increase in burn up of fuel relative to a pure fission cycle.
  - During this process more fission products are transmuted and actinides are burned.
  - Depleted uranium is a good fuel.
- The result is a once through system (no reprocessing) with a significant reduction in the waste-to-energy production ratio (e.g. a factor of four), and potentially better economics than the use of specialized waste burning.

# Socioeconomic Studies of Fusion Power (ORNL & Partners)

---

- **Objective:** An assessment of the projected competitiveness of future fusion-based electrical power generation with fission, fossil, and renewable electricity sources.
  - Principal Jerry Delene.
  - Completed: 9/99.
- **Objective:** Study of options to deploy large fusion power plant including hydrogen production and co-generation.
  - Principals: Boeing, Center for Energy and Environment at Princeton University, Duke E&ES, TVA, and ORNL).
  - To be completed by 12/99, no funding in FY00.

# Socioeconomic Studies of Fusion Power (PNL)

---

- **Objective:** Establish economic benefit of fusion research and fusion energy using macroeconomic models.
- **Focus:** Economic impact on GNP and balance of trade using parametric variations of
  - Busbar cost of fusion electricity;
  - Time of introduction and growth of fusion electricity.
- **Timeframe:** on-going for several years.

# Socioeconomic Studies of Fusion Power (U. of Wisconsin)

---

- **Objective:** To calculate the energy payback ratio and CO<sub>2</sub> gas emission rates from fusion and natural gas electrical power generating stations (Supports a graduate student)
- **Plans for FY 99:** To calculate the energy payback ratio and CO<sub>2</sub> emission rates for DT fusion and comparison to coal, LWR, and wind electrical generating facilities.
- **Plan for FY 00:** To apply the same analysis techniques to natural gas power plants and compare them to fusion, fission, coal, and wind power plants (\$24k allocated in FY00).

Extra

# There Is a Large World-Wide Activity in Energy Projections for the Next Century

---

- US DOE Energy Information Agency:
    - \* National Energy Modeling System (NEMS);
    - \* World Energy Projection System (WEPS);
    - \* Annual Energy Outlook reports
  - International Energy Agency (IEA):
    - \* Energy Technology System Analysis Programme (ETSAP);
    - \* World Energy Outlook reports.
  - International Atomic Energy Agency:
    - \* DECADES project.
  - International Institute for Applied Systems Analysis (IIASA) and World Energy Council (WEC).
  - Pacific Northwest Laboratory (PNL):
    - \* MiniCAM 98.7
- ⇒ Recent emphasis is on ecologically driven scenarios

# Global Energy Modeling -- Observations

---

- Large-scale studies are performed by groups recognized world-wide as experts with sophisticated models. This expertise does not exist in the fusion program.
  - \* **Strategies for fusion:**
    - (1) Fund a large-scale study by an expert group (probably too expensive);
    - (2) Partial support for one of the studies to include fusion in their cases. This is the approach with the PNL study.
    - (3) Use one or more of these scenarios as is and investigate the role of fusion.
- Fusion is absent from energy supplies considered
  - \* It is not clear if this is due to the charter of the study or any technical reasons by the authors.
  - \* In either case, there is a clear need to make a case for fusion.
  - \* Strategy will depend on why fusion is absent and other potential long-term sources are included.

# Case for Fusion in Global Energy Strategy

---

- There is a divergence of opinion in the fusion community of why fusion is not considered in energy forecasting scenarios:
  - \* Fusion is not demonstrated
    - Strategy: Make a case that fusion is technically feasible and can be realized in a reasonable time-scale.
  - \* Energy is not the goal of the program;
    - Strategy: We need to verbalize the dual pillars of fusion research (energy and science).
  - \* Fusion COE is too high;
    - Strategy: Examine other sources of energy included in various scenarios and develop comparable fusion costs.
  - \* Lack of fundamental information on fusion potential;
  - \* Invisibility of fusion scientists in energy projection field.
    - Strategy: One or a few fusion scientists dedicated to outreach activity (needs funding).

# How to Make a Case for Fusion -- A Strategy

---

- Present activities are too small to make much impact.
- In order to make a case for fusion, sufficient investment has to be made or we will always remain outside of these circles.
- It takes a coordinated national activity focused on making fusion visible in the energy planning and forecasting circles.
  - 3 to 5 FTP level of effort, consisting of part-time activities from several scientist from major fusion institutions.
  - National effort should lead to a consensus view rather than highlighting advocacy group positions.
  - Establish credibility and expertise through high-quality research and publishing papers in scientific journals of this field.
  - A circle of scientists that attend all major conferences/symposia in energy forecasting field.

# How to Make a Case for Fusion --Initial Study

---

- Thorough review of various energy forecasting scenarios (builds bridges with energy forecasting groups).
- Choose one of the scenarios (such as IIASA/WEP) for initial study.
- Examine other sources of energy included in various scenarios and develop comparable fusion development scenarios and costs.
  - \* Promotes interaction with other disciplines;
  - \* Argument for fusion can be made in a similar context.
- Develop a case that fusion can contribute to all energy usage categories (not solely electricity).
- Examine energy projection scenarios both in global and regional (e.g., North American) scale.

# National Power Plant Studies Program Initiated Two-years Projects in 1/99

---

- **Fusion Neutron Source Study:**
  - Non-electric applications of fusion, specially those resulting in near-term products may lead to new clients and to additional resources for fusion.
  - A concept definition phase is in progress to identify promising concepts and provide necessary information for proceeding further.
- **ARIES-AT:**
  - Assess impact of advanced technologies as well new physics understanding & modeling capabilities on the performance of advanced tokamak power plants.
- **Integrated IFE Chamber Study: (to start in 1/2000)**
  - Identify and explore design window for IFE chambers.

# Non-Electric Applications of Fusion Neutrons

---

- Typical applications ( $\sim 10^{19}$ - $10^{21}$  n/s) :
  - \* Transmutation of fission waste (Actinides);
  - \* Hybrids for fuel and/or energy production;
  - \* Fusion materials and engineering testing.
- Post-cold-war additions:
  - \* Tritium production;
  - \* Burning of plutonium from dismantled weapons.
- Recent application ( $\sim 10^{11}$ - $10^{13}$  n/s)
  - \* Radioisotope production;
  - \* Medical radiotherapy;
  - \* Detection of explosives.

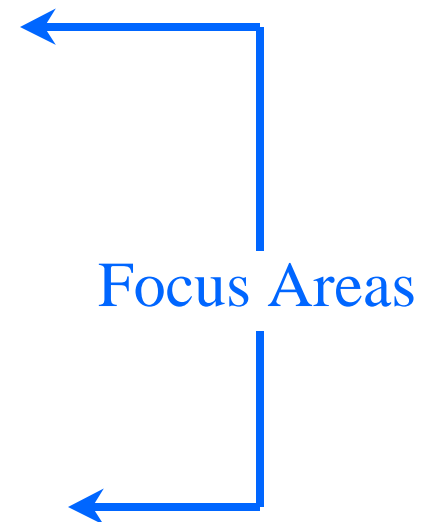

# Fusion Pu and Actinide Burner

---

- There is a large stockpile of weapon-grade Pu (in US and Russia) as well as spent fuel.
- National Academy review about 4 years ago recommended burning weapons Pu in present LWRs as MOX (mixed-oxide fuel).
  - \* This is not a viable solution for the Russian.
- Other approaches for burning Pu and actinide are under study by fission and accelerator communities (mostly internal funding).
- No urgency in congress or administration for weapon-grade Pu problem as NRC's time table of five years is very near. DOE Waste program is focused on burial of actinides.
- Congress has authorized some funding for this activity this year (“for ATW and other advanced technologies”)

# Scope of Fusion Pu and Actinide Burner Study

---

- A compilation and assessment of the engineering and nuclear performance of the various concepts proposed for neutron-source applications including fusion, fission and accelerator systems;
- An assessment of the environmental, safety and licensing implications of fusion neutron-source applications such as plutonium disposition and radioactive waste transmutation;
- Identification of the political issues associated with certain applications (e.g., association with nuclear weapons, attacks from environmental and/or fission communities, etc.)
- A preliminary report will be available by end of December.

# Preliminary Conclusions

---

- There are many different transmutation fuel cycles and many different blankets proposed.
- There is no established set of criteria. Most concepts can be re-optimized based on different criteria, so comparison is difficult.
- The most fundamental distinction is the existence of external neutron source leading to critical versus sub-critical blanket operation.
- Most performance parameters mainly depend on blanket and fuel cycle choices (spectrum of external source matters little).
- Work by other communities has focused on performance not on safety, licensing, reliability, cost, etc.
- This is NOT a near-term option for fusion because of the safety and licensing issues and the associated need for component data base and reliability. (ATW is not a near-term solution neither.)

# Optimization Strategy for ARIES-AT

---

$$\text{Capital Cost} \propto \sum c_i M_i + \sum c_k P_k$$

## Traditional:

- Reduce recirculating power (maximize bootstrap current).
- Reduce mass of fusion core ( $M_i$ ) by increase fusion power density & neutron wall loading (higher performance physics and higher performance magnets).

## Additional New emphasis:

- Minimize thermal power by maximizing thermal efficiency (high-temperature blanket utilizing Brayton cycle).
- Reduce unit cost of components,  $c_i$  and  $c_k$  :
  - Use advanced manufacturing techniques;
  - High level of safety assurance allows for a much smaller nuclear grade boundary;
  - Trade-off performance versus cost.

# Main Features of ARIES-AT<sup>2</sup>

## (Advanced Technology & Advanced Tokamak)

---

- **High Performance Very Low-Activation Blanket:** New high-temperature SiC composite/LiPb blanket design capable of achieving ~60% thermal conversion efficiency with small nuclear-grade boundary and excellent safety & waste characterization.
  - **Higher Performance Physics:** reversed-shear equilibria have been developed with up to 50% higher  $\beta$  than ARIES-RS and reduced current-drive power.
  - **Higher Performance Magnets:** High- $T_c$  superconductors.
- ⇒ Present strawman operates at the same power density as ARIES-RS, higher  $\beta$  was used to reduce the peak field at the magnet.
- Reduce unit cost of components through **advanced manufacturing techniques.**

# Our Vision of Magnetic Fusion Power Systems Has Improved Dramatically in the Last Decade, and Is Directly Tied to Advances in Fusion Science & Technology

---

**Estimated Cost of Electricity (c/kWh)**

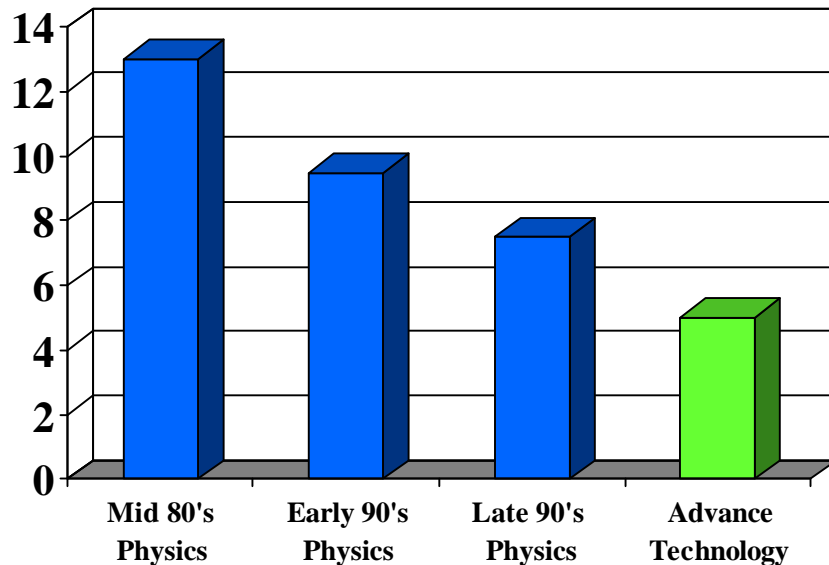

**Major radius (m)**

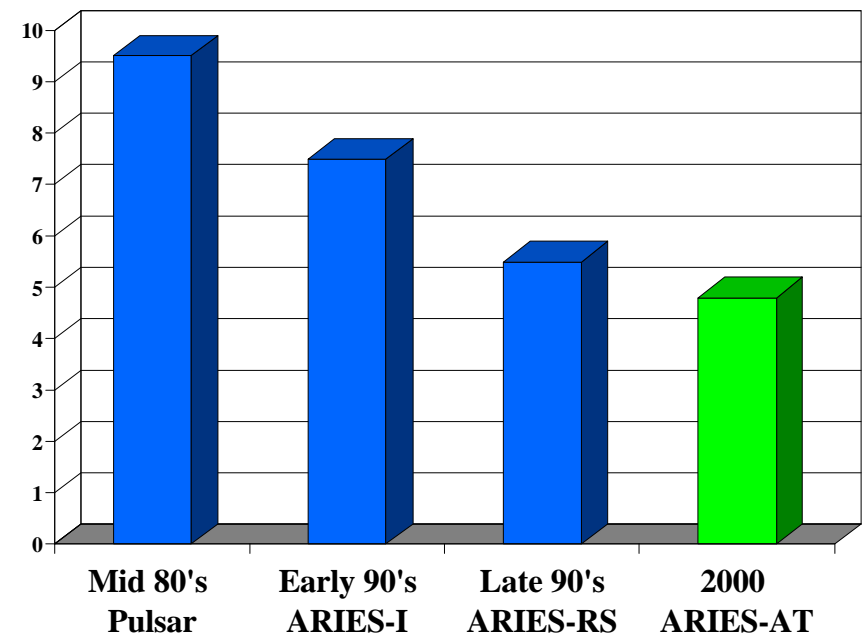

**Preliminary ARIES-AT parameters:**

Major radius: 4.8 m  
 Toroidal  $\beta$ : 6.4%  
 Wall Loading: 4.3 MW/m<sup>2</sup>

Fusion Power 1,740 MW  
 Net Electric 1,000 MW  
 COE 5 c/kWh

# ARIES-I Introduced SiC Composites as A High-Performance Structural Material for Fusion

- Excellent safety & environmental characteristics (very low activation and very low afterheat).
- High performance due to high strength at high temperatures ( $>1000^{\circ}\text{C}$ ).
- Large world-wide program in SiC:
  - New SiC composite fibers with proper stoichiometry and small O content.
  - New manufacturing techniques based on polymer infiltration results in much improved performance and cheaper components.
  - Recent results show composite thermal conductivity (under irradiation) close to  $15\text{ W/mK}$  which was used for ARIES-I.

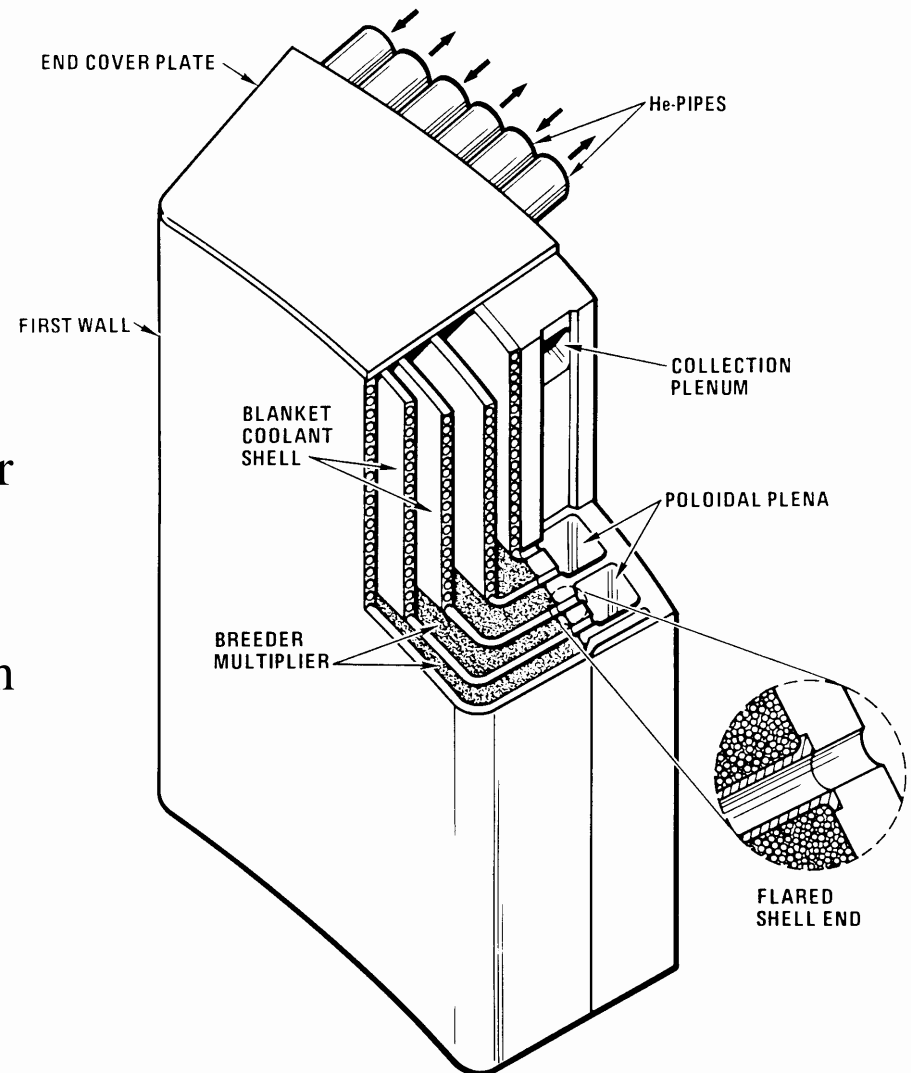

# ARIES-AT<sup>2</sup>: SiC Composite Blankets

- Simple, low pressure design with SiC structure and LiPb coolant and breeder.
- High LiPb outlet temperature (~1100°C) and high thermal efficiency of ~60%.
- Simple manufacturing technique.
- Very low afterheat.
- Class C waste by a wide margin.

## Outboard blanket & first wall

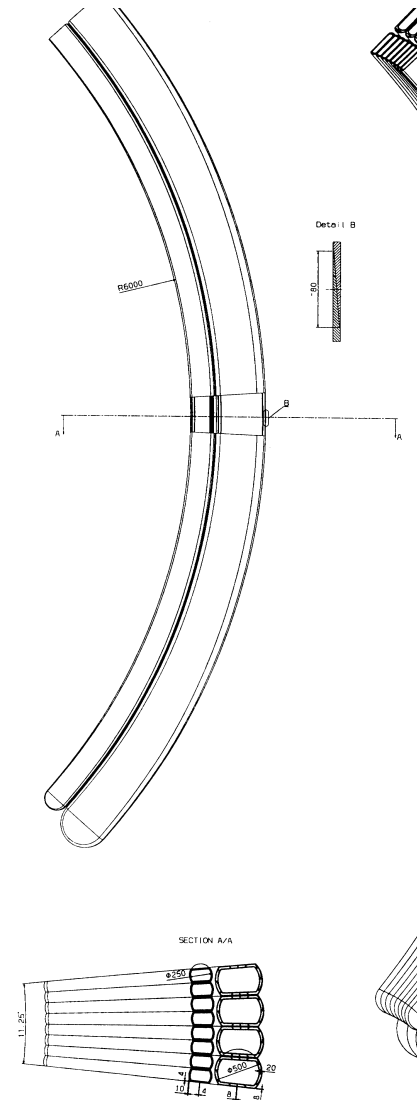
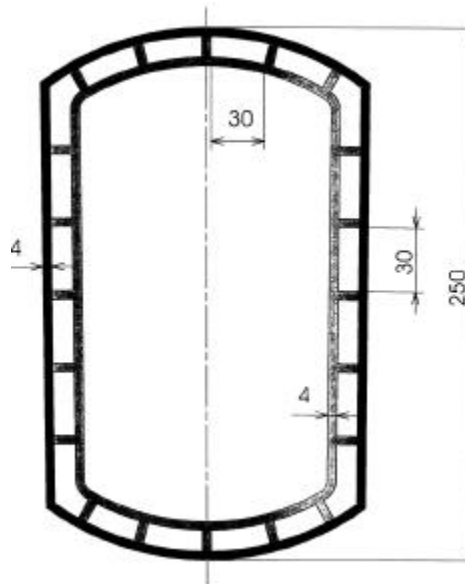

# Recent Advances in Brayton Cycle Leads to Power Cycles With High Efficiency

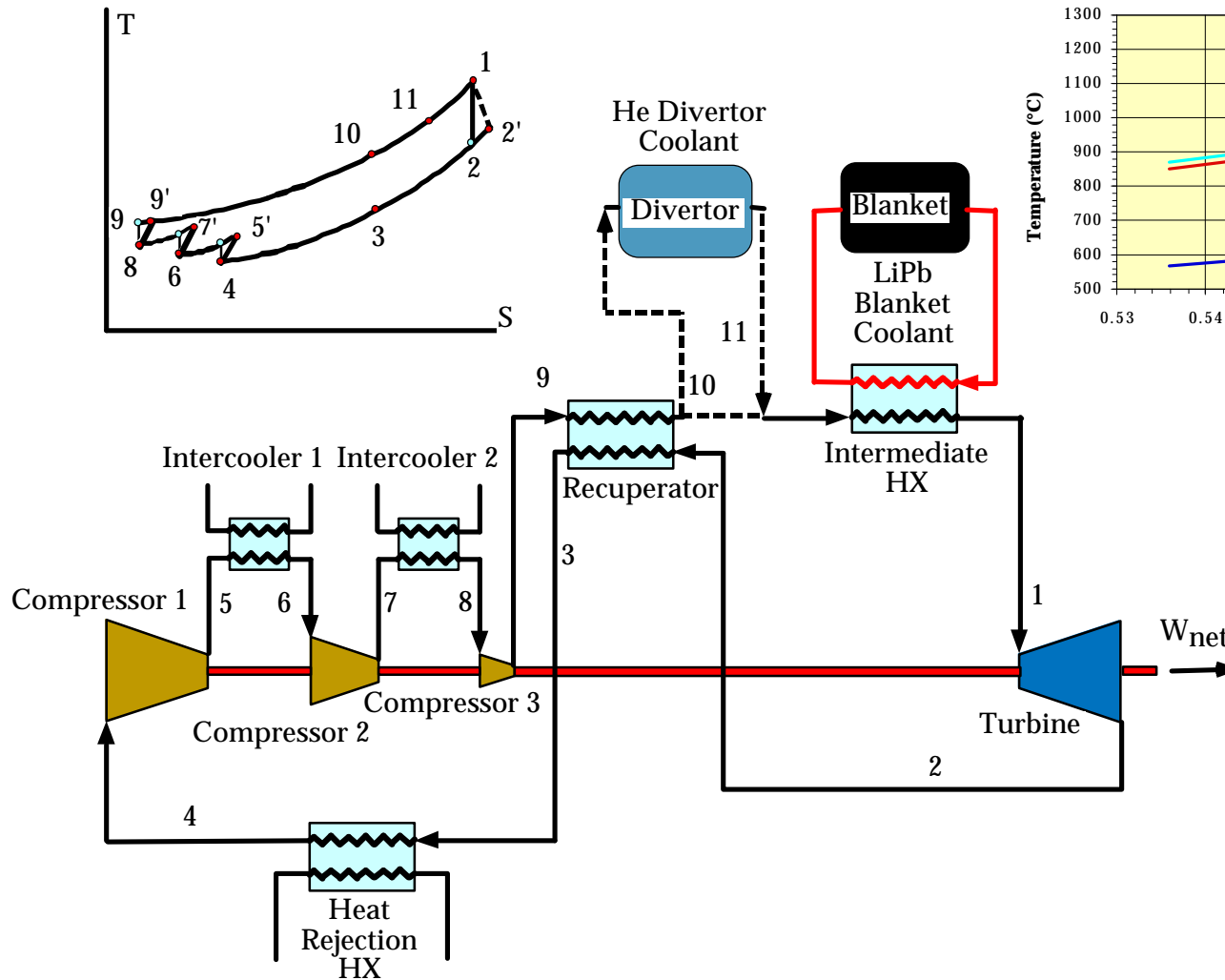

Brayton Cycle He Inlet and Outlet Temperatures as a Function of Required Cycle Efficiency

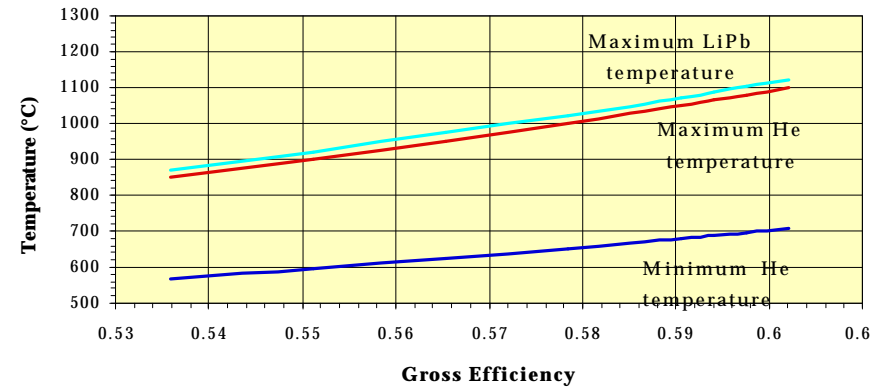

- Key improvement is the development of cheap, high-efficiency recuperators.

# ARIES-AT<sup>2</sup>: Physics Highlights

---

- Use the lessons learned in ARIES-ST optimization to reach a higher performance plasma;
  - Using  $> 99\%$  flux surface from free-boundary plasma equilibria rather than  $95\%$  flux surface used in ARIES-RS leads to larger elongation and triangularity and higher stable  $\beta$ .
- Eliminate HHFW current drive and use only lower hybrid for off-axis current drive.
- Perform detailed, self-consistent analysis of plasma MHD, current drive and divertor (using finite edge density, finite  $p'$ , impurity radiation, etc.) (In progress)
- ARIES-AT blanket allows vertical stabilizing shell closer to the plasma, leading to higher elongation and higher  $\beta$ . (In progress)

# The Integrated IFE Study Will Identify and Explore the Design Window for IFE chambers & Define R&D Needs

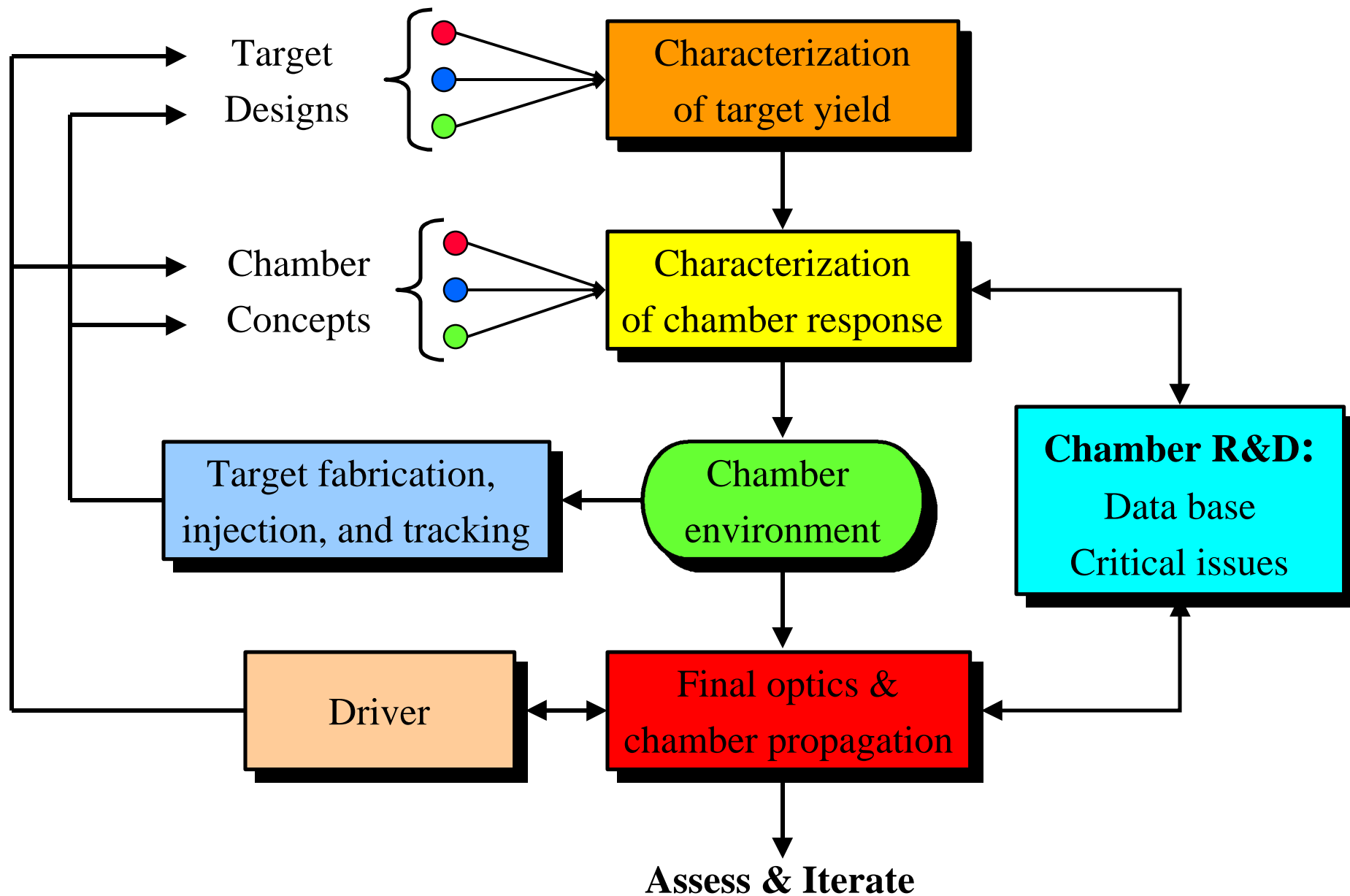

# National Power Plant Studies Program Plan for FY 2000

---

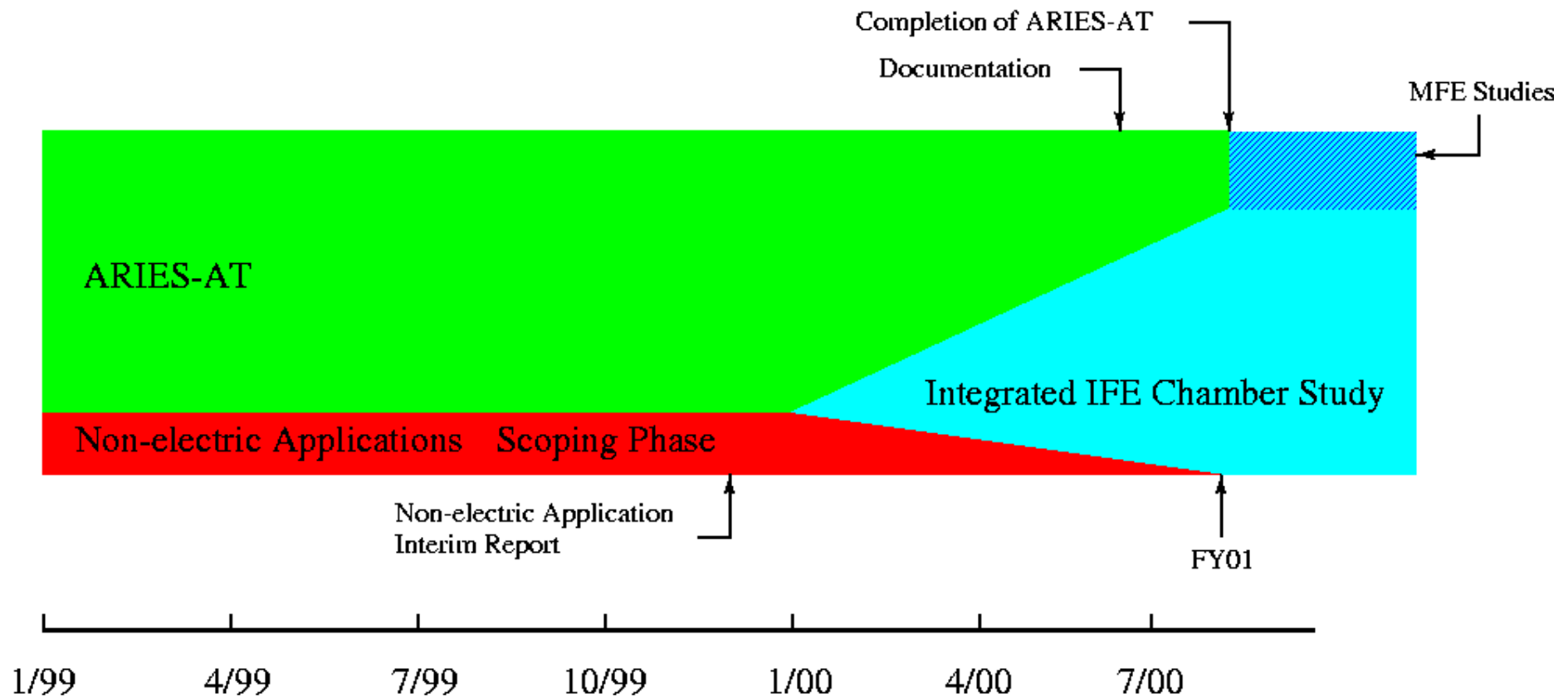

# ARIES Outreach Activities

---

- International Material & Design Town Meeting on SiC composites (Jan 18-19, 2000) ORNL.
- Collaboration between FIRE and ARIES teams.
- Collaboration with the European Power Plant Study
- Socioeconomic studies in Japan (somewhat different in scope than those done in US, more design oriented).

## PAC Feedback of 6/99

---

- “The PAC believes that the perspective presented by the VLT provides too little weight to emerging concepts.”
- “We recommend that the group also perform some roll-back exercises, in which a desirable endpoint is defined. This exercise, as a complement to the roll-forward approach, aids in the identification of key research areas of possibly large payoff.”